

Design and Analysis of Automatic Washroom Cleaning Machine

Arvinth¹, Ajithkumar², Koorimugesh³, Jakir Hussain⁴

^{1, 2, 3}student, Department of Electronics and Communication Engineering
KPR Institute of Engineering and Technology Arasur, Coimbatore.

⁴Asst.professor(SL.G), Department of Electronics and Communication Engineering
KPR Institute of Engineering and Technology Arasur, Coimbatore.

¹arvinth.sankar1998@gmail.com, ²ajithkumar151999@gmail.com,

³koorimugesh28@gmail.com, ⁴gkjakirhussian@gmail.com

Abstract

There are many washrooms provided by the authority in the rural and urban areas but because of limited number of resources it is not possible to maintain all the cleaning assemblies from all areas so because of this we lag to maintain cleaning in these areas so all the things taken into consideration here decided to work on cleaning in washrooms of rural and urban areas. Here decided to work on a mechanism i.e. Fabrication of Advanced controlled Indian toilet sheet cleaning system. In modern world their lack man power to clean the toilet cleaning. Most of the disease is spread from toilet only. To maintain the toilet clean people can automatic toilet and normal people can use it. The disease mainly spread from washroom. Our main aim to develop the automatic toilet cleaner without man power. Now day's people are not ready to clean the washroom and shortage of man power. To overcome this problem automatic machine more useful. Over main to create low cost machine.

Keywords: Toilet Cleaning Machine, Modelling, Analysis, and Stress

I.INTRODUCTION

This project will be helpful for cleaning of washrooms where there is no provision of any cleaning assembly so It will

be easier to place cleaning assembly with low cost, effective, power optimistic and less maintenance. This project uses rack and pinion arrangement along with washer to clean complete system. Here is another assembly i.e. cleaning of dome with the help of some motors. This system uses high torque motor to clean complete floor. This complete system is power saving system and with the help of limited time it is possible. This system is cost optimistic and with the help of limited source it is possible to maintain all the things. This project will be useful at home, schools, colleges, hospitals, companies, factories and anywhere workplace. Urban area development prime important to the world. The robots are developed to enhance and improve the life lifestyle urban area people. The hygienic of human are much need and on that way automatic washroom cleaning machine are developed. Due to the lack of labour, hygienic purpose and also the safety of labour the machine is developed. Other way the operation of machine is simple, power requirement and cost effectiveness. The components used are low power micro controller, 12Vdc motor, etc every cost and power effective. This lavatory cleaning robot is designed especially to clean urinals. It is equipped with different sensors which provides necessary control data and ensure the working of robot without harming

human being. The robot has a line follower integrated with a manipulator.

II. LITERATURE REVIEW

1. With the advancement of technology, robots are getting more attention of researchers to make life of mankind comfortable. This paper presents the design, development and fabrication of prototype Smart Floor Cleaning Robot (CLEAR) using IEEE Standard 1621

(IEEE Standard for User Interface Elements in Power Control of Electronic Devices employed in Office/Consumer Environments). Subject machine works in self operated mode as well as in manual method along with other features like planning for specific time and bag less dust container with auto-dirt disposal mechanism. This work can be very useful in improving life style of mankind

2. Manual work is overcome by the robot technology and many of the related robot appliances are being used widely. Here represents the technology that proposed the working of robot for floor cleaning. This floor cleaner robot can work in any of two modes i.e. "Automatic and Manual". All hardware and software operations are assisted by AT89S52 microcontroller. This robot facilitates sweeping and mopping task. RF modules have been used for wireless communication between remote (manual mode) and robot and having range 50m. This robot is inbuilt with IR sensor for obstacle detection and automatic water sprayer pump. Four motors are used, two for cleaning, one for water pump and one for wheels. Dual relay circuit used extensively to drive the motors one for water pump and another for cleaner. In previous work, there was no automatic water sprayer executed and works only in automatic mode. In the automatic mode machine control all the operations itself and change the lane in case of difficulty detection and moves back. In the manual mode, the key pad is used to perform the desired task and to operate robot. In manual mode, RF component has been used to pass on and receive the information between remote and robot and display. The information

related to the hurdle exposure on LCD. The whole circuitry is connected with 12V battery.

3. Household service robots have long been a staple of science fiction and commercial visions of the future. Until recently, we have only been able to speculate about what the experience of using such a device might be. Current domestic service robots, introduced as consumer products, allow us to make this vision a reality. This paper presents ethnographic research on the actual use of these products, to provide a grounded understanding of how design can influence human-robot interaction in the home. We used an ecological approach to broadly explore the use of this technology in this context, and to determine how an autonomous, mobile robot might "fit" into such a space. We offer initial implications for the design of these products: first, the way the technology is introduced is critical; second, the use of the technology becomes social; and third, that ideally, homes and domestic service robots must accept to each other

4. Modelling studies on surface roughness of laminated glass cut by abrasive water jet hemavathy s, t anilkumar, bijayalakshmidas, 2019

The machine need water sprinkling machine to spray the water on the washroom and this method is studied from the glass cutting above reference and using that the floor is cleaned. Also we study that how optimizes the power to machine .we can fit two tank one fill water and another one is fill liquid .The tank are slipped and two connection are give and two dc motor are used. Timing are fixed in micro-controller for the operation of the motor to spray water and liquid from the tank.

IV . WORKING OF TOILET CLEANINGMODEL

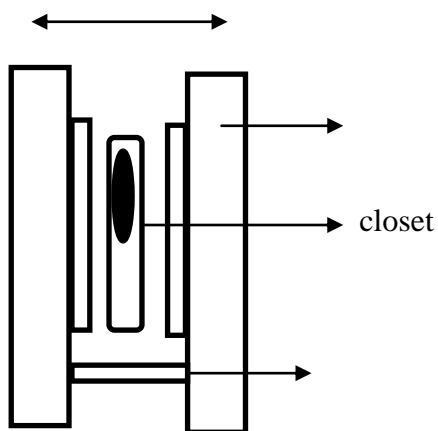

This system operates on the battery having size 12volt and 8 amperes. This system involves two different Rack and pinion mechanisms for dome cleaning system and third additional mechanism for water controlling. We are having total 9 motors, out of them 4 motors for vertical to and fro movement, and 4 motors for foot rest cleaning, and 1 motor for water controlling.

There are total 5 switches to control 5 different operations are as follows: -

1. Basement Cleaning
2. Water Flows

III.BLOCK DIGRAM

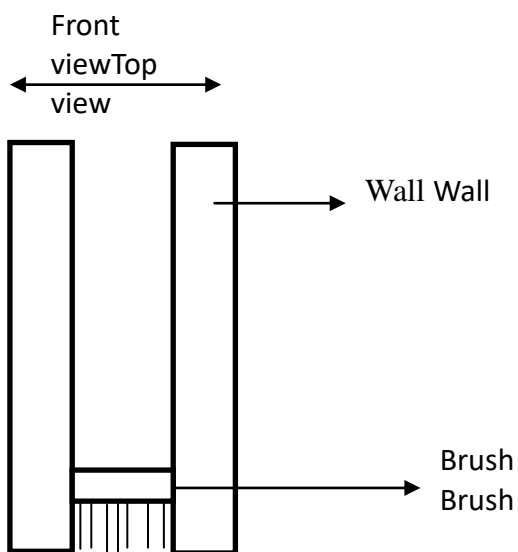
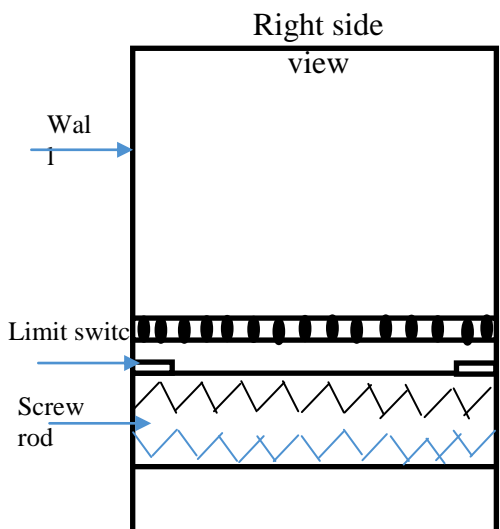

The automatic washroom cleaner machine uses the Micro-controller, IR Sensor, Battery, Timers, Rack and Pinion gear setup, Brushes. The experimental setup uses the battery for the operations which is to be performed. Initially, when the battery is switched ON, the timer gets activated for the cleaning of washroom closet and floor for those different programming is coded. When the battery gets started the brush setup which is attached to the motor and it rests on the rack and pinion gear setup. It started to move along its directional path which is coded. It uses the IR Sensor for the detection of any obstacles before if it senses the closet doom the programming gets next step and activated the vertical movement of the single brush which is in the centre and the remaining brushes rests the same. After the timing gets completed the vertical moment of the Brush gets completed and retrieved to its original position and completed the horizontal cleaning of the floor. Once the IR Sensor detected the wall which is opposite the timer program also gets to the reverse or original position. This makes the whole setup to be in the original position.

VI.COMPARATIVEANALYS

Location-college washroom
Sweeper name-zyx

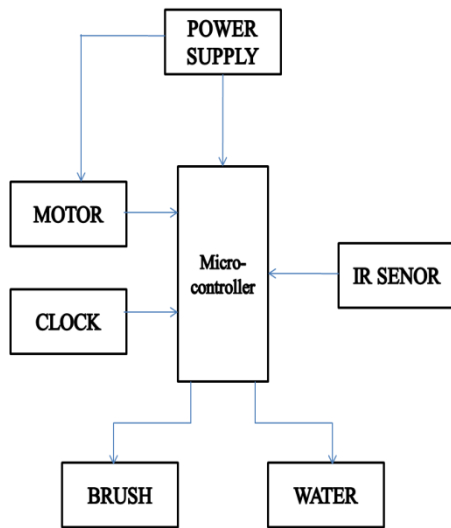

S.N O	OPERATIO N	TIME FOR MANNUAL OPERATIO N	TIME FOR AUTOMATIC OPERATION
1	Foot Rest Cleaning	3 min	1.5-2 min
2	Dome cleaning	2.5 min	1-1.5 min
3	water sprinkling	1 min	0.3-1.5 sec
4	inner surface cleaning	2 min	1-1.3 min

V.EXPERIMENTAL SETUP

The experimental setup is fabricated as shown in Fig. 1of automatic restroom cleaner.Itconsists of rack and pinion setup for movement, two dc motors for rotating the pinion, battery for providing power , brushes for cleaning, micro-controller for storing and sending signals for the operation, one infra-red sensor for sensing, a sprinkler for spraying the water and soap solution mixture.

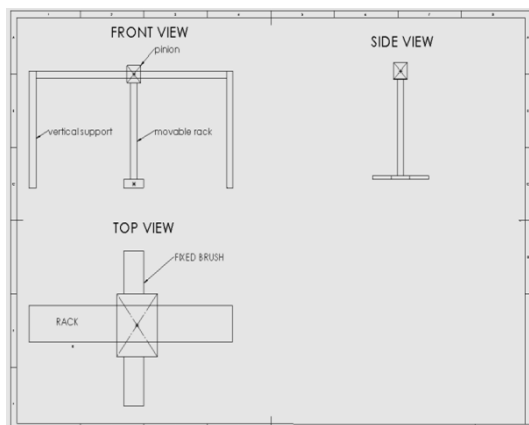

VII.COMPONENT DESCRIPTION

A. Controller

Used Adriano UNO microcontroller is used in this project. It is the central processing unit of the project.

B.Motor Driver

Motor Driver IC L293D is a dual H-bridge motor driver integrated circuit. There are two motor driver used to control the two dc gear motor used in line follower, pump motor and a dc motor .

C. IR Sensor

IR sensor is designed to detect and response to the presence of a object or a black line.

D. Water Pump

Water pump is a device that moves fluids by mechanical action. Pumps are commonly rated by flow rate, outlet pressure in meters of head etc.

E. Passive Infrared Sensor

Objects that generate heat also generate infrared radiation and those objects

include animals and the human body. PIR detects such radiation generated.

F. DC Motors

A device that converts electrical energy into mechanical energy or imparts motion.

G. Servo Motor

It is a self-contained electrical device that rotates parts of a machine with high efficiency and great precision. The output shaft of this motor can be moved to a particular angle

VIII. CONCLUSION

The developed fabrication according to the design exhibits the expected results. As per our proposed working condition we are able to clean the restrooms without the help of any external humans involved in cleaning process. With simple mechanical setup arrangements and program, the cleaner will be able to cover large floor areas as well as find its way in and out of small corners. As the cleaner traverses the room, the sweeper installed in it will manage to pick up a significant amount of dirt. The nozzle in this setup gives the high pressurized water and also in the wide spread to large areas. In other hand, Manual Sweeping might not be that effective as it will not be picking up everything in as it is not in sight but using the automatic floor cleaner it can be done easily. The conventional work of the cleaner uses simple and reliable setup's makes this to used in the day-to-day routine life to eliminates the human efforts from cleaning the restrooms. In the current situation, the most of the cleaning companies manufacture's the cleaning machines for both industrial and housing purpose. But those machines are made for the use of cleaning the floors and vacuuming the place to absorb the dust from the place in industries to clean the working environment. Those machines uses the

electricity to clean the surface and the machines are not fully automated which are used in industries for the purpose of cleaning. The housekeeping machines which are in use for cleaning purpose are only used to clean the dust from the floors but toes are also not automated any of the housekeeping or the industrial cleaning machines aren't made cleaning restrooms or washrooms. During implications, we have some calculation errors and programming errors by overcoming those errors now we are able to make the restroom cleaner to work in a perfect condition. In these we are able to clean the restrooms in effective manner and now we have attached a small water container which is used for the cleaning. The time taken to develop the machine is very.

IX. REFERENCES

- Manya Jain, Pankaj Singh Rawat, Assist. Prof. Jyoti Morbale International Research Journal of Engineering and Technology (IRJET) - Apr -2017.
- Modelling studies on surface roughness of laminated glass cut by abrasive water jet hemavathy s, t anilkumar, bijayalakshmidas, 2019
- Automatic Floor Cleaner Manya Jain¹, Pankaj Singh Rawat², Assist. Prof. Jyoti Morbale, 2017
- Design and fabrication of floor cleaning machine -a review dhiraj m. bankar student, department of mechanical engineering S.b.patil College of engineering, vangali, indapur, pune.
- Jens-Steffen Gutmann, Kristen Culp, Mario E. Munich, Paolo Pirjanian - The Social Impact of a Systematic Floor Cleaner.
- Ganeshram V., Achudhan M., Design and mold flow analysis of piston cooling nozzle in automobiles, Indian Journal of Science and

Technology, v-6, i-SUPPL.6, pp-4808-4813, 2013

- Ganeshram V., Achudhan M., Synthesis and characterization of phenol formaldehyde resin as a binder used for coated abrasives, Indian Journal of Science and Technology, v-6, i-SUPPL.6, pp-4814-4823, 2013.
- Achudhan M., Prem Jayakumar M., Mathematical modeling and control of an electrically-heated catalyst, International Journal of Applied Engineering Research, v-9, i-23, pp-23013-

